

**3010**



**500308**

Bartscher GmbH  
Franz-Kleine-Str. 28  
D-33154 Salzkotten  
Germany

Phone: +49 5258 971-0  
Fax: +49 5258 971-120  
**Service hotline:** +49 5258 971-197  
[www.bartscher.com](http://www.bartscher.com)

Version: 1.0

Date of preparation: 2025-01-22

**Original instruction manual**

## Safety Indications

This appliance has been manufactured in accordance with technical standards currently in force. However, the appliance may be a source of hazards if used improperly or contrary to its intended purpose. All persons using the appliance must consider information included in this instruction manual and observe safety instructions.

- Exercise extreme caution when operating the appliance; die blades are very sharp and they pose **the risk of cutting!**
- Keep your hands and fingers away from the cutting mechanism!
- Switch the appliance on only after its complete and correct assembly. To this end, read indications in section '**Assembly**'.
- Control movable elements of the appliance regularly. Make sure there are no doubts as to their operational condition, that they do not seize, and thus do not negatively influence the appliance's operation. Before continuing to operate, order the repair or replacement of damaged parts.
- Before cutting chips, make sure the C clamps are safely fixed to long and short studs, and the die is safely secured to the appliance's frame.

## Operating personnel

- This appliance is not intended to be used by persons (including children) with limited physical, sensory or mental capabilities, nor by persons with limited experience and/or limited knowledge.
- Children should be supervised to ensure that they are not playing with or switching the appliance on.

## Intended Use

This appliance is only intended for use described in the operating instructions, with the supplied and approved components.

Any other use is considered against the intended purpose. The manufacturer shall not be liable for any damage due to unintended use. In such cases the responsible party shall only be the user/operator.

The following is an intended purpose:

- Cutting potato chips and wedges.

## Technical Data

|                                |                         |
|--------------------------------|-------------------------|
| <b>Name:</b>                   | <b>Chip cutter 3010</b> |
| Art. No.:                      | <b>500308</b>           |
| Material:                      | stainless steel         |
| Die/stamp material:            | stainless steel         |
| Number of dies/stamps:         | 4                       |
| Dimensions (W x D x H), in mm: | 425 x 155 x 335         |
| Weight, in kg:                 | 2,6                     |

We reserve the right to implement technical modifications.

## Version / Characteristics

- Designed for:
  - table-top mounting
  - wall mounting
- Dies/stamps:
  - 6 mm chips
  - 9 mm chips
  - 13 mm chips
  - Potato wedges

EN

## Appliance Operation

You may use the chip cutter to effortlessly and on your own, produce potato wedges and chips in 3 different sizes.

## List of Components of the Appliance

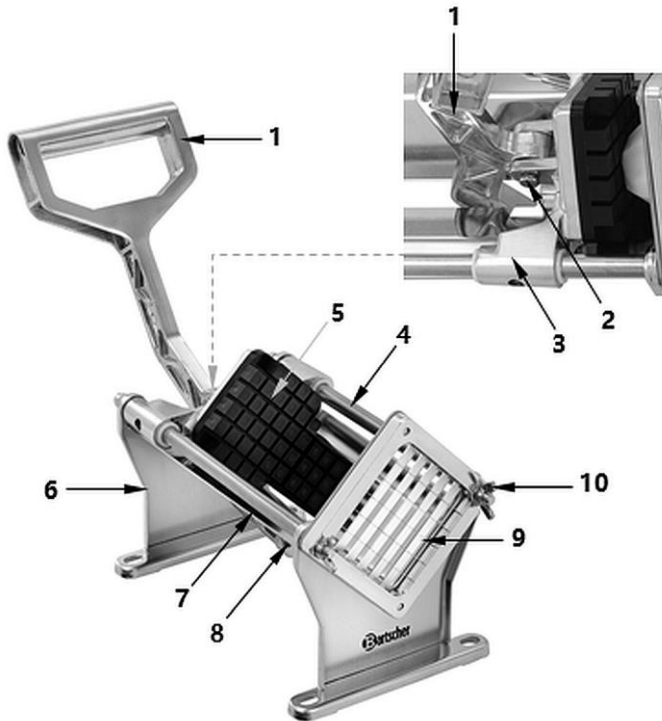

Fig. 1

- |                                  |                              |
|----------------------------------|------------------------------|
| 1. Operating lever               | 2. Stud (long) with C clamp  |
| 3. Feeding frame (guiding frame) | 4. Slide rail                |
| 5. Stamp                         | 6. Frame                     |
| 7. Connection plate              | 8. Stud (short) with C clamp |
| 9. Die                           | 10. Wing nut (2 pcs)         |

## Equipment (included in delivery)

### ATTENTION!

#### Damage to parts due to improper assembly

When fitting the die/stamp cutting set, make sure the blades are oriented with their sharp ends towards the product to be cut.

Die/stamp  
6 mm chips

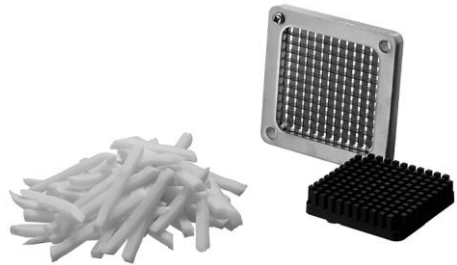

Fig. 2

EN

Die/stamp  
9 mm chips



Fig. 3

Die/stamp  
13 mm chips



Fig. 4

## Die/stamp Potato wedges



Fig. 5

## Assembly

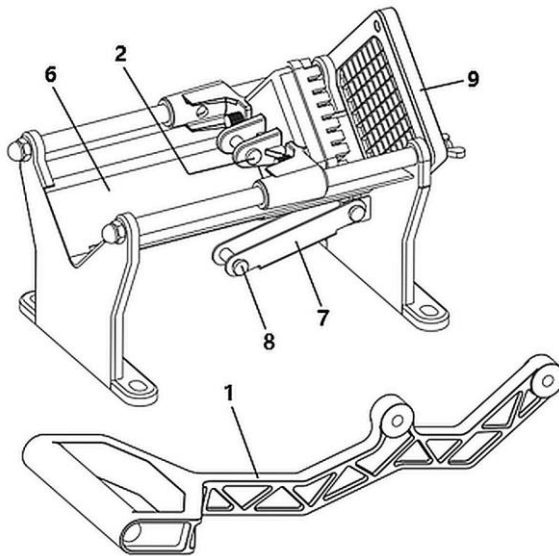

EN

Fig. 6

1. Remove C clamp from the long stud (2) at the back of the pusher. Remove C clamp from the short stud (8), which is located at the free end of the connection plate (7).
2. Align the middle assembly opening of the handle (1) with openings in the assembly bracket at the back of the pusher's block; insert the long stud and secure it with C clamp. To place the C clamp on the stud and retain the stud in place, use tweezers with slim tips and press the clamp until it engages.

3. Align the bottom opening of the handle with opening in the connection plate (7), which is already assembled at the bottom of the frame. Insert the short stud (8) and secure it with C clamp. To place the C clamp on the stud and fix the stud, use tweezers with slim tips and press the clamp until it engages.

## Table-Top Mounting

You may set and mount the chip cutter to the table-top with suitable rubber feet (**not part of the deliver**).

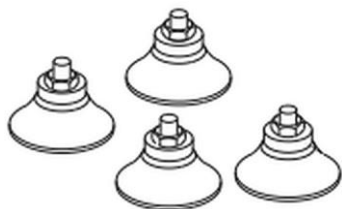

Fig. 7

1. Fix the rubber feet (example shown in the Figure) in the frame openings, using suitable nuts.
2. Then set the chip cutter in a selected location and press it down for the rubber feet to suck well to a table-top.

EN

## Wall Mounting

Another possibility for mounting the cutter in manner safe for a user is wall mounting.

1. Before mounting the chip cutter on a wall, check the parameters of a wall where the cutter is to be installed.

### ATTENTION!

**Do not mount the chip cutter on drywalls not on panels.**

When mounted on a solid wall surface, such as concrete or stone, you get the guarantee that the chip cutter will not come loose during operation.

### NOTE!

**Fixing material is not included in the delivery.**



Fig. 8

2. For wall mounting use 4 M8x60 anchor bolts with expansion sleeves (Fig. to the left).

3. Hold the chip cutter against the wall and use openings in the frame to mark boring points in a selected location.
4. Bore 4 holes in the wall in marked points.
5. Insert 4 anchor bolts with expansion sleeves in the bored openings.
6. Then, introduce anchor bolts with expansion sleeves into the wall only to the depth that makes it possible to fix the chip cutter with the frame on them.
7. Hang the chip cutter on anchor bolts. Insert washers on both sides of openings in the frame.
8. Then fix nuts on anchor bolts.

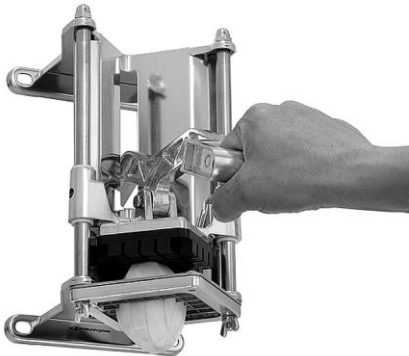

Fig. 9

9. Place a suitably large container directly underneath the chip cutter for the purpose of collecting cut chips or other products.
10. Pull the handle downwards and cut chips.

## Operation



### WARNING

#### **Injury hazard due to sharp die blades!**

Exercise caution so that your hands and fingers are not in the area of the die.

1. Before each use, clean the appliance thoroughly, especially the parts that come into contact with food. Follow indications in section '**Cleaning**'.

2. Wash and dry potatoes.

You may peel them or leave them in peels.

You may also use any other hard vegetable to prepare chips.

The appliance is intended for vegetables with diameter of up to 11 cm and length of up to 15 cm.

IN the case of too large potatoes or vegetables, we recommend to slice them into smaller chunks so that they may be entirely cut.

EN

3. Place a suitable container underneath the die (e.g., a bowl, a bucket) to collect cut fries.

4. Place prepared potatoes (or other vegetables) on the die, with the cutting surface directed downwards.

5. To cut potatoes, pull the handle with both hands quickly and evenly towards the die/downwards.

6. Repeat the process until the required amount of potatoes is cut.

## Stamp/Die Replacement

By factory default, there is the 9 mm die and stamp assembled on the appliance's frame. If needed, they may be replaced at any time with the 6 mm or 13 mm stamp/die, or with the stamp/die for potato wedges.

When replacing, proceed as described below.

### 1. Die:

- remove 2 wing nuts of the die,
- carefully remove the die,
- fit the required die,
- fix the fitted die with the removed wing nuts.

### NOTE!

**The die is executed with two openings for it to be correctly placed on the appliance's frame.**

### 2. Stamp (black):

- manually or with a screwdriver, undo both knurled screws at the back wall of the connection plate,
- remove the stamp,
- fit the stamp that fits in size with the fitted die,
- use the removed knurled screws to re-tighten the fitted stamp onto the connection plate.

## Cleaning



### WARNING

#### **Injury hazard due to sharp die blades!**

Exercise extreme caution when replacing dies.

Wear safety gloves, resistant to cutting.

### **ATTENTION!**

**Abrasive, solvent, caustic or alkaline cleaning agents may damage the surface of components, cause pittings or blunt die blades.**

Use only mild washing agents.

1. Clean the chip cutter thoroughly after each use.
2. Before cleaning, remove the die/stamp from the frame, following indications in section '**Stamp/Die Replacement**'.
3. Remove the handle from the frame. Perform the actions described in section '**Assembly**' in reverse order.
4. Clean the removed parts in warm water, using a gentle washing agent and a plastic dish-washing brush.
5. Rinse the parts thoroughly with fresh water.
6. Use a soft, damp cloth to wipe the appliance's frame.
7. Dry cleaned surfaces and elements before re-assembling them; to this end, use a soft, lint-free cloth or leave them to dry in open air.
8. Before storing, cover all metal parts of the appliance with a food-grade silicone spray or grease.